

Doc No	CCM56XX SPECIFICATION	REV	PAGE	DATE
9100-0110		C	1 OF 41	2008. 12. 15.

Contactless IC Card Collecting Machine

With Security Cartridge having its own I.D

KYTronics Corp.,Ltd

3rd Floor, A-Dong,

Twin Town-Bldg, 703-2.

Gojan-Dong, AnSan-City,

Kyung Ki-Do, Korea

Tel : 82 - 31 - 485 - 9480

Fax : 82 - 31 - 485 - 9488

E-mail : sales@kytronics.co.kr

<http://www.kytronics.co.kr>

Doc No	CCM56XX SPECIFICATION	REV	PAGE	DATE
9100-0110		C	2 OF 41	2008. 12. 15.

REVISION HISTORY

No	DATE	DESCRIPTION	REV	PAGE
1	2008.01.03	First Edition	A	41
2	2008.12.15	Modify the Technical Drawing		

Doc No	CCM56XX SPECIFICATION	REV	PAGE	DATE
9100-0110		C	3 OF 41	2008. 12. 15.

MODEL NAME INFORMATION

C C M - 5 6

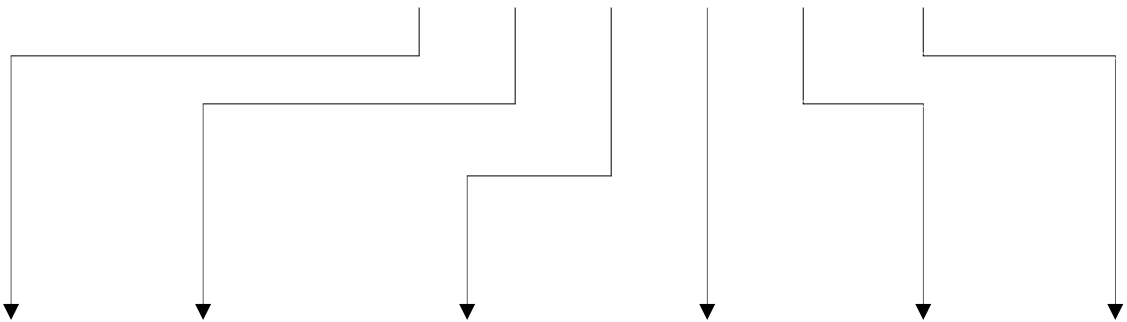

Interface	Function	MS / IC / RF	Track	Option	Capacity		Option II
RS232C	Collecting Machine	0 : - 1 : MS Only 2 : MS & IC-Contact 3 : MS & RF 4 : MS & IC & RF 5 : IC Only 6 : RF Only 7 : IC-Contact & RF	0 : Without Magnetic 1 : ISO 1 Track 2 : ISO 2 Track 3 : ISO 3 Track 4 : ISO 1,2 Track 5 : ISO 1,3 Track 6 : ISO 2,3 Track 7 : ISO 1,2,3 Track	0: Without bezel 1: LOW-CO Short bezel 2: HI-CO Short bezel 3: LOW-CO & Shutter 4: HI-CO & Shutter 5: Shutter	A: 0.76T B: 0.84T C: 1.0T	D: 0.76T E: 0.84T F: 1.0T	C: CASE
					600 PCS	1000 PCS	

Doc No	CCM56XX SPECIFICATION	REV	PAGE	DATE
9100-0110		C	4 OF 41	2008. 12. 15.

C O N T E N T S

Overview -----

System Block Diagram -----

Specification -----

RF Card Process -----

Communication Interface -----

Technical Drawing -----

Command Detail -----

Error Detail -----

Precautions -----

Doc No	CCM56XX SPECIFICATION	REV	PAGE	DATE
9100-0110		C	5 OF 41	2008. 12. 15.

OVERVIEW

This model can be used for the RF card conforming to the MIFARE.

The CCM-5600 has Serucity cartridges having its own I.D in it.

So, nobody can take the card by hand without breaking the cartridge, and also remote monitoring of cards and cartridge management system is possible.

This model simplified the command for Mifare card, minimize the delay time occurs in the communication data processing, and improved the speed.

This model has the following advantages:

- 1) Remove the latency due to the user-based card exchange, by collecting 600 to 1000 pcs at a time.
- 2) Two different type of card collecting using two stackers.
- 3) Prevent any burglary of cards in the cartridge
- 4) Allow remote monitoring of number of cards in each cartridges, and easy cartridge management system.

As an automatic issuing machine, this model can be used in issuing most types of prepaid cards, credit card and debit card in AFC, Parking, Highway and financial area.

Doc No	CCM56XX SPECIFICATION	REV	PAGE	DATE
9100-0110		C	6 OF 41	2008. 12. 15.

SYSTEM BLOCK DIAGRAM

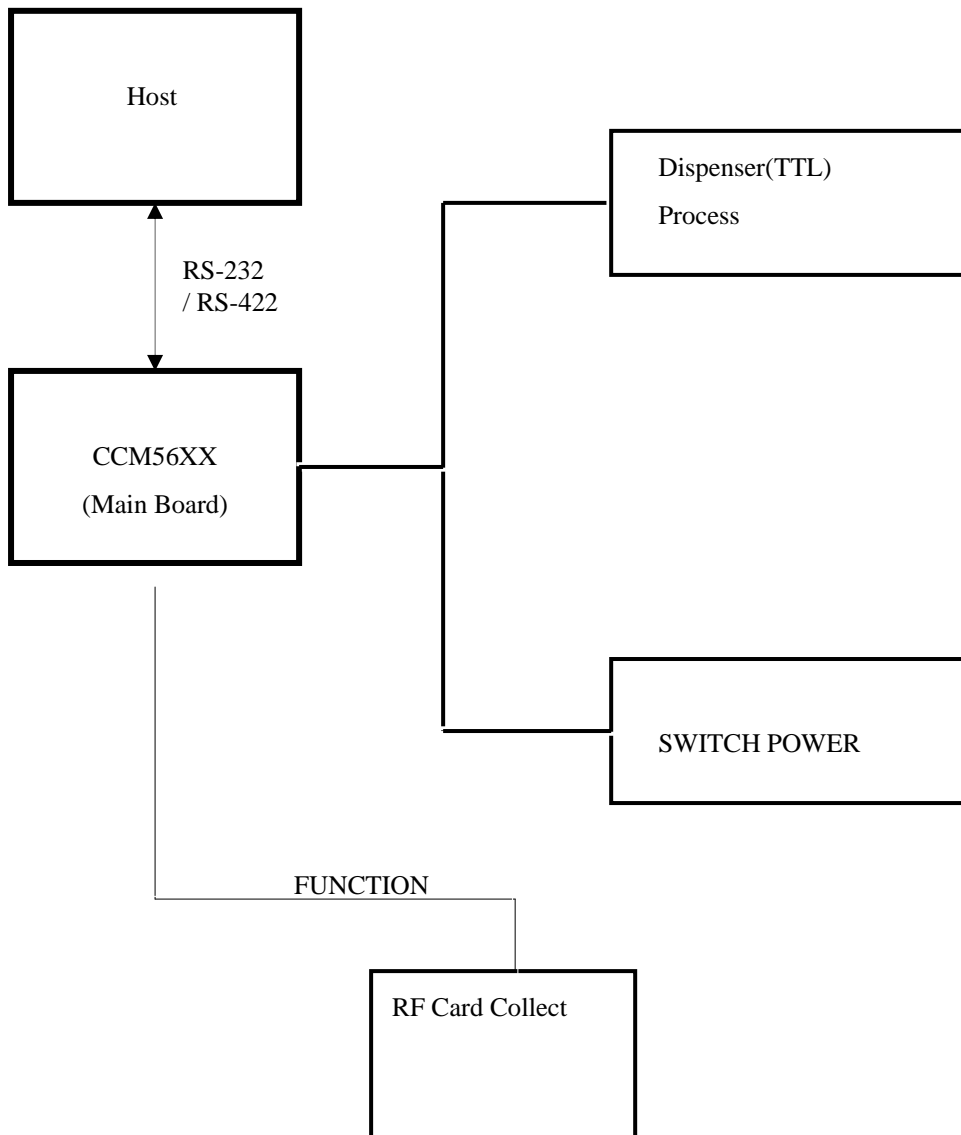

Doc No	CCM56XX SPECIFICATION	REV	PAGE	DATE
9100-0110		C	7 OF 41	2008. 12. 15.

◆ *RS – 232 Connection*

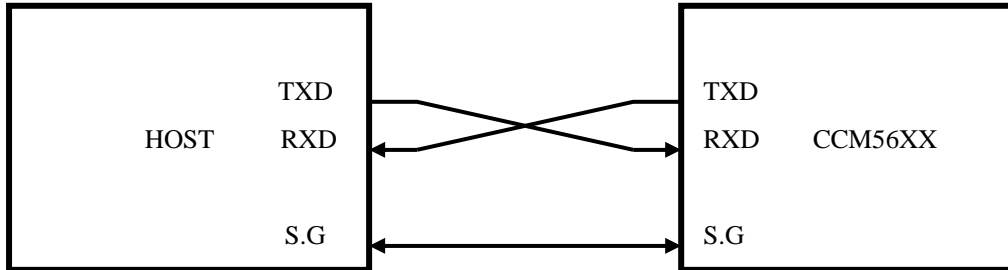

CASE 1) Part Number : RED-9S-LNA(HIROSE)

Pin No	INDEX	Remark
2	RXD	Receive
3	TXD	Transmit
5	S.G	Signal Ground

◆ *RS422 Connection*

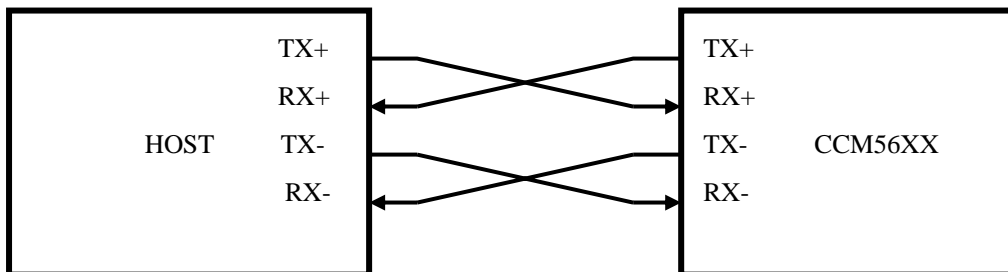

CASE 1) Part Number : RED-9S-LNA(HIROSE)

Pin No	INDEX	Remark
1	TX+	
4	RX+	
6	TX-	
8	RX-	

Doc No	CCM56XX SPECIFICATION	REV	PAGE	DATE
9100-0110		C	8 OF 41	2008. 12. 15.

SPECIFICATIONS

◆ *basic functions*

	Spec	Remark
Dimension	Refer to Page 16	
Weight	About 18 kg	
Input power	AC 110 ~ AC 220V Free voltage	
Card Feeding Speed	510mm/Sec \pm 10%	
M.T.B.F	100,000 HR or more (Electronic parts only)	
M.C.B.F	1,000,000 cycles or more (except some wear parts such as rubber roller and belts)	

◆ *Environment Requirements*

Operating Locus : In door use only

Ambient Temperature

Storage : -20 °C to 70 °C(No functional error to be found in 12 hours after returning to normal environment)

Operating : 5 °C to 50°C (In 0°C to +5°C range, all specifications but 'Warped card' to be satisfied)

Ambient Relative Humidity

Storage : 0% to 95% RH(No functional error to be found in 12 hours after returning to normal environment)

Operating : 5 % 90% RH(No Condensation)

Vibration

: Amplitude 2mm, 10 to 50 Hz in X, Y, Z directions for 30min, 2G or less

Shock Endurance

: 30G, 11ms

Doc No	CCM56XX SPECIFICATION	REV	PAGE	DATE
9100-0110		C	9 OF 41	2008. 12. 15.

◆ *Controller Environment*

Communication

- : RS422 OR RS232C Interface
- : Baud Rate – 9600 BPS
 - 19200 BPS
 - 38400BPS(Default)
 - 57600BPS
- : 8Data bit, 1 Start bit, None Parity bit, 1 Stop Bit

DIP-Switch Setting

: To provide basic operation and function setting of terminal, DIP(Dual In type Package) switch in the main board has selection of main program and function of communication speed setting.

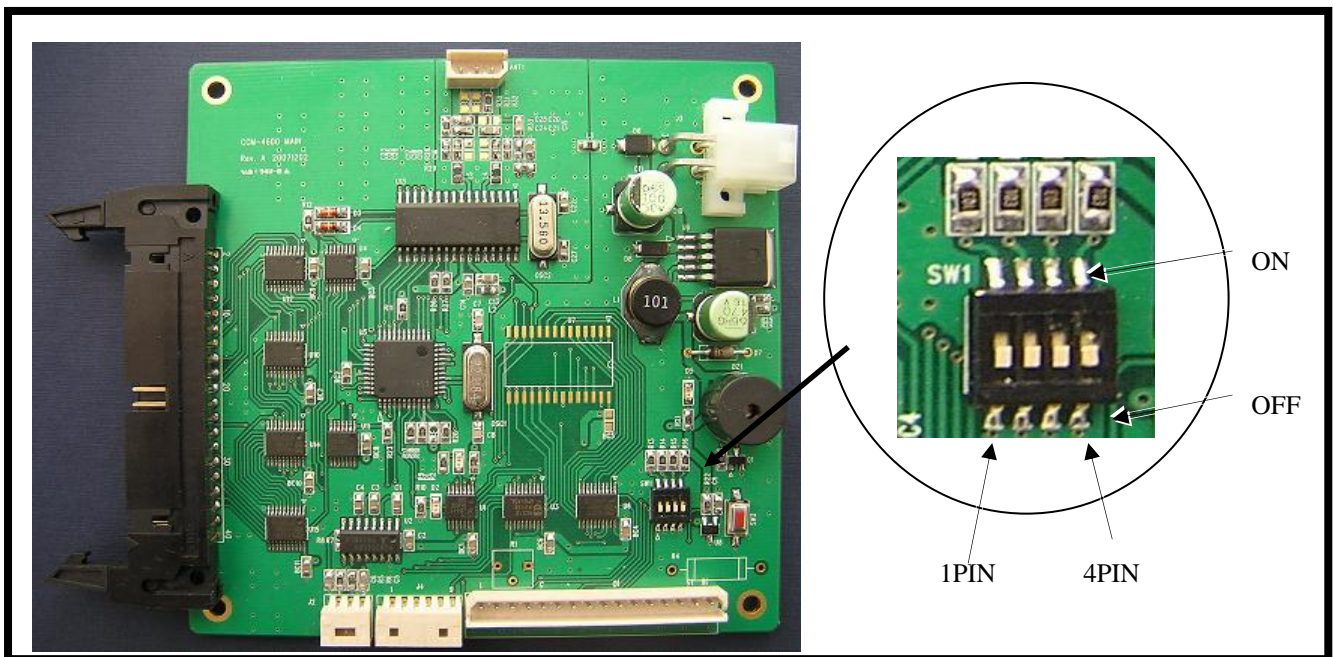

Pin No. 1	Pin No. 2	Pin No. 3	Pin No. 4	Baud Rate	Note
ON	ON	OFF	OFF	9600 BPS	
ON	OFF	OFF	OFF	19200 BPS	
OFF	ON	OFF	OFF	38400 BPS	Default
OFF	OFF	OFF	OFF	57600 BPS	

Doc No	CCM56XX SPECIFICATION	REV	PAGE	DATE
9100-0110		C	10 OF 41	2008. 12. 15.

RF CARD PROCESS

The RF module supports most of RF cards conforming with the ISO14443-3 TypeA(MIFARE Card) with 8 Kbits memory.

◆ *Processing time* : Once Block

Command	Parameter	Time (mSec)		Note
		Type	Max	
Card Read	1 Block	100		Without card moving
Card Write	1 Block	150		Without card moving, With Verify
Card Decrement	1 Block	120		Without card moving, With Verify
Card Increment	1 Block	120		Without Card moving, With Verify

◆ *Operating Frequency*

Operating Frequency : 13.56 MHz

Data Transfer Baud : Baud rate 106Kbaud

◆ *Operating range of the Antenna*

Guar. Operating range : All distances in the range of 0 ... 50 mm from the antenna board.

Typical operating range : 0 ... 65 mm

◆ *Power Consumption*

Supply Voltage	Operating Voltage	Operating Current	
		Type	Max
+ 5 V	+5V +10% -5%	165mA	255mA

Doc No	CCM56XX SPECIFICATION	REV	PAGE	DATE
9100-0110		C	11 OF 41	2008. 12. 15.

COMMUNICATION INTERFACE

◆ *Communication Method*

Asynchronous, Half duplex.

Baud Rate : 9600 – 57600Bps , Default : 38400Bps

Start Bit : 1Bit

Data Length : 8Bit

Parity : None

Stop Bit : 1Bit

◆ *Communication Protocol Format*

1 Command Frame Format.

SOH	Null	Length	STX	CMD	DATA	ETX	BCC
1 byte	1 byte	2 byte	1 byte	3 byte	N byte	1 byte	1 byte

2 Positive Response Frame Format

SOH	Null	Length	STX	CMD	GOOD	0x01	DATA	ETX	BCC
1 byte	1 byte	2 byte	1 byte	3 byte	2 byte	1 byte	1 byte	1 byte	1 byte

(N byte: variable length)

3 Negative Response Frame Format

SOH	Null	Length	STX	CMD	E-Code	0x00	ETX	BCC
1 byte	1 byte	2 byte	1 byte	3 byte	2 byte	1 byte	1 byte	1 byte

4 BCC (Check Sum)

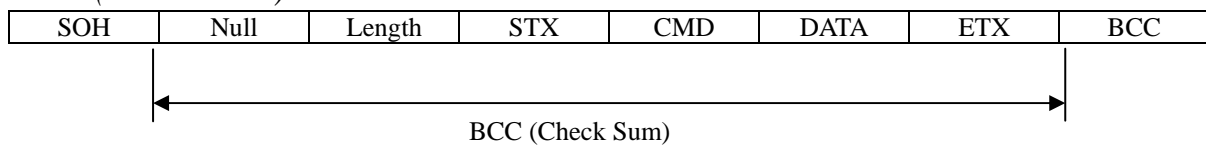

Command Frame BCC = Null ^ Length ^ STX ^ CMD ^ DATA ^ ETX.

Positive Response BCC = Null ^ Length ^ STX ^ CMD ^ GOOD ^ 0x01 ^ DATA ^ ETX.

Negative Response BCC = Null ^ Length ^ STX ^ CMD ^ E-Code ^ ETX.

Doc No	CCM56XX SPECIFICATION	REV	PAGE	DATE
9100-0110		C	12 OF 41	2008. 12. 15.

5. Explanatory note of technical words

Name	Detail
Null	Reserved. Always 0x00.
Length	Data Length from the CMD to DATA.
CMD	Instruction Code (3 Bytes)
GOOD	Normal Execution : 0x0000 (2 Bytes)
E-Code	Command Failed: Refer to "Error Code" (2 Bytes)
BCC	Check Sum.

<Length>, <E-Code>

High Byte	Low Byte
-----------	----------

6. Control Characters

Name	Hex Value	Detail
SOH	0x01	Start of Header
STX	0x02	Start of Text
ETX	0x03	End of Text
ENQ	0x05	Enquiry
ACK	0x06	Positive Acknowledge
NAK	0x15	Negative Acknowledge
CAN	0x18	Cancel

7 COMMUNICATION SEQUENCE / TIMING

7.1 Command

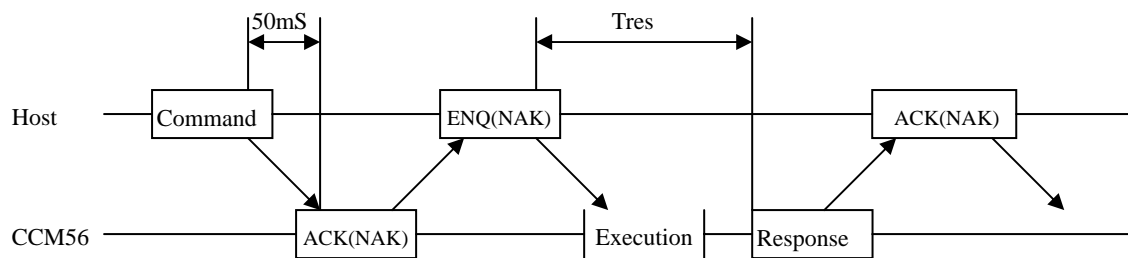

7.2 Inquiry

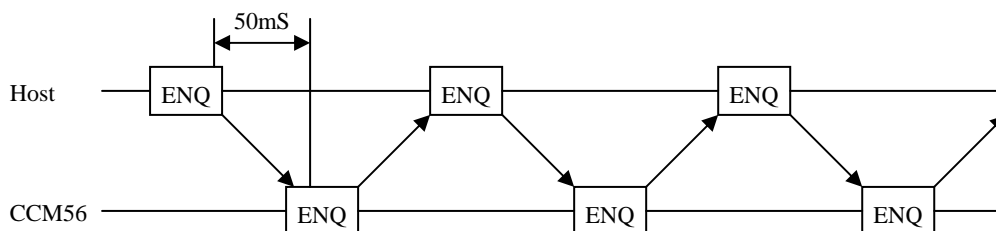

Doc No	CCM56XX SPECIFICATION	REV	PAGE	DATE
9100-0110		C	13 OF 41	2008. 12. 15.

7.3 Sequence

7.3.1 General

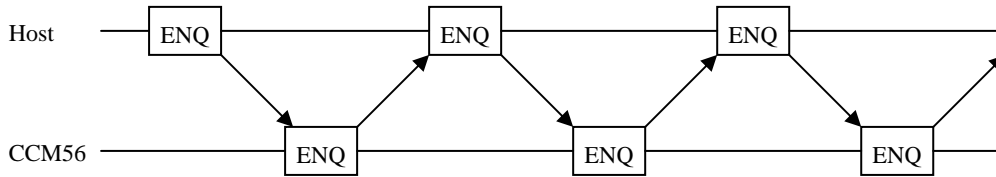
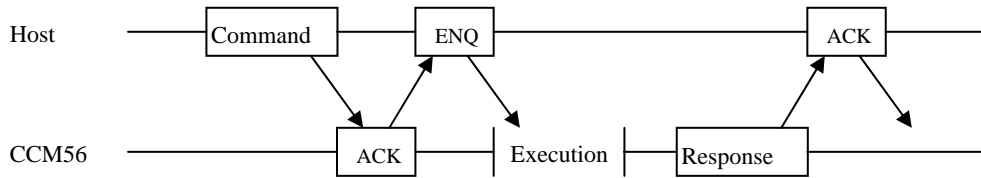

7.3.2 Event

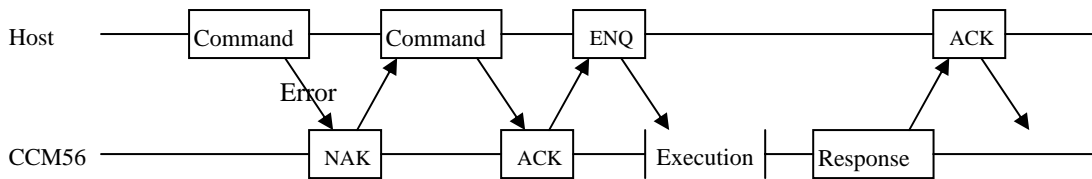

Doc No	CCM56XX SPECIFICATION	REV	PAGE	DATE
9100-0110		C	14 OF 41	2008. 12. 15.

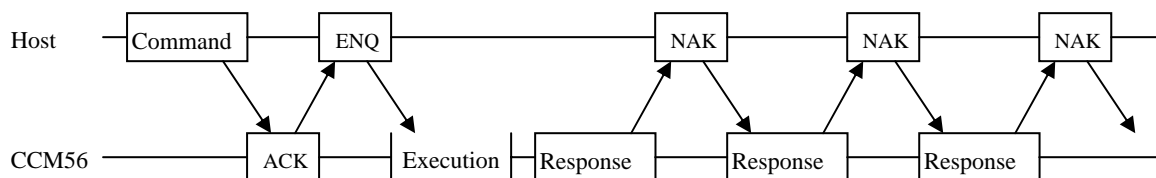
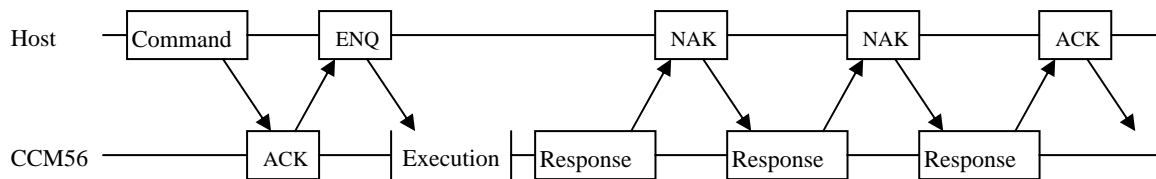
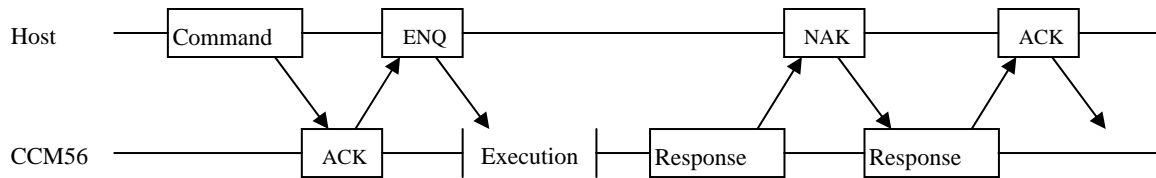
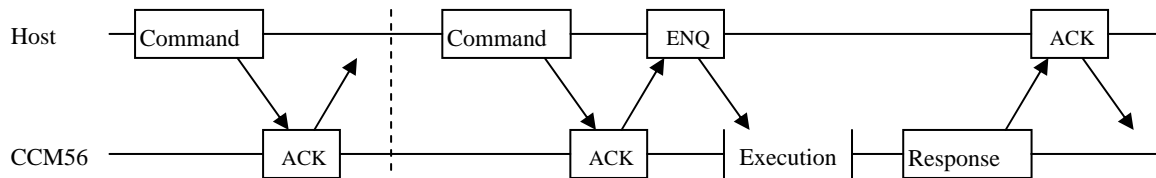
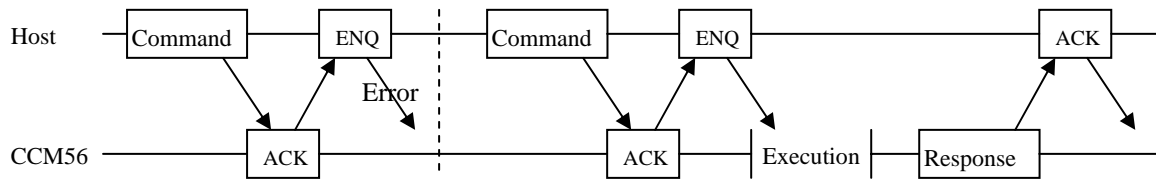
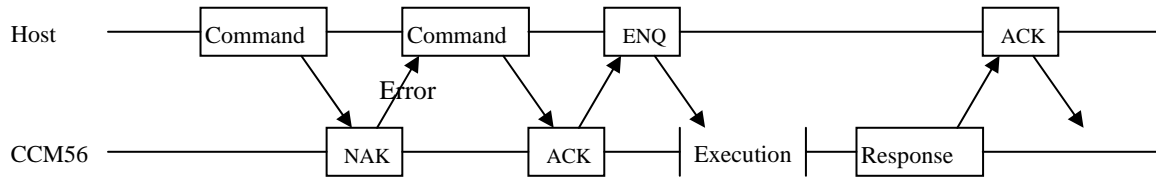

Doc No	CCM56XX SPECIFICATION	REV	PAGE	DATE
9100-0110		C	15 OF 41	2008. 12. 15.

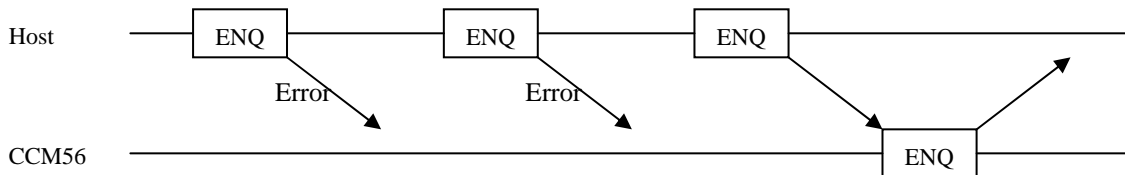
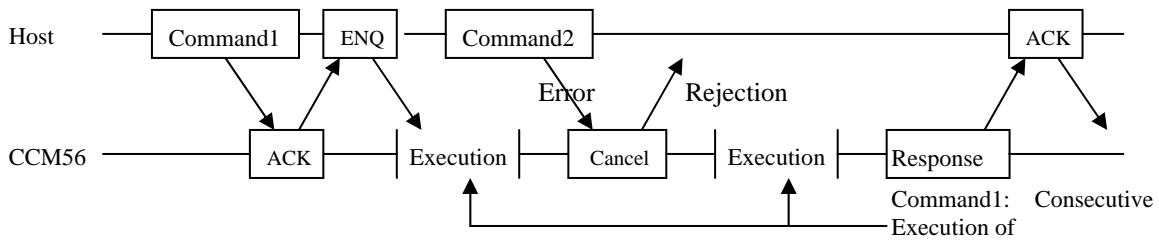
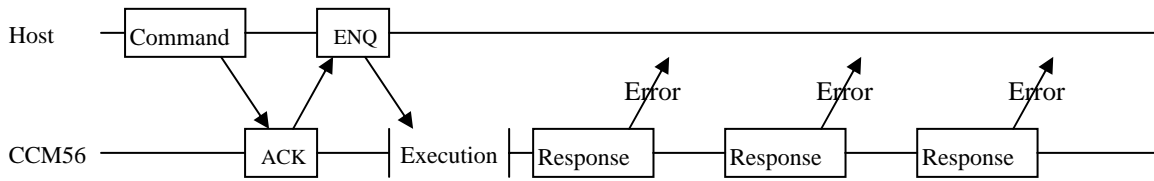
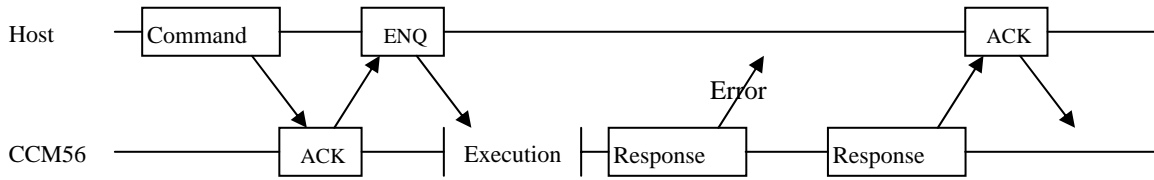

- When received the NAK packet consecutively.

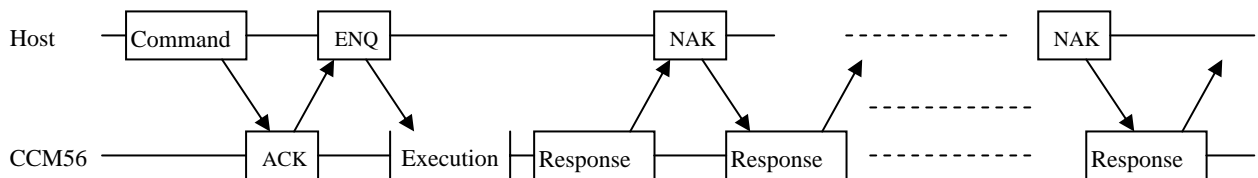

Doc No	CCM56XX SPECIFICATION	REV	PAGE	DATE
9100-0110		C	16 OF 41	2008. 12. 15.

TECHNICAL DRAWING

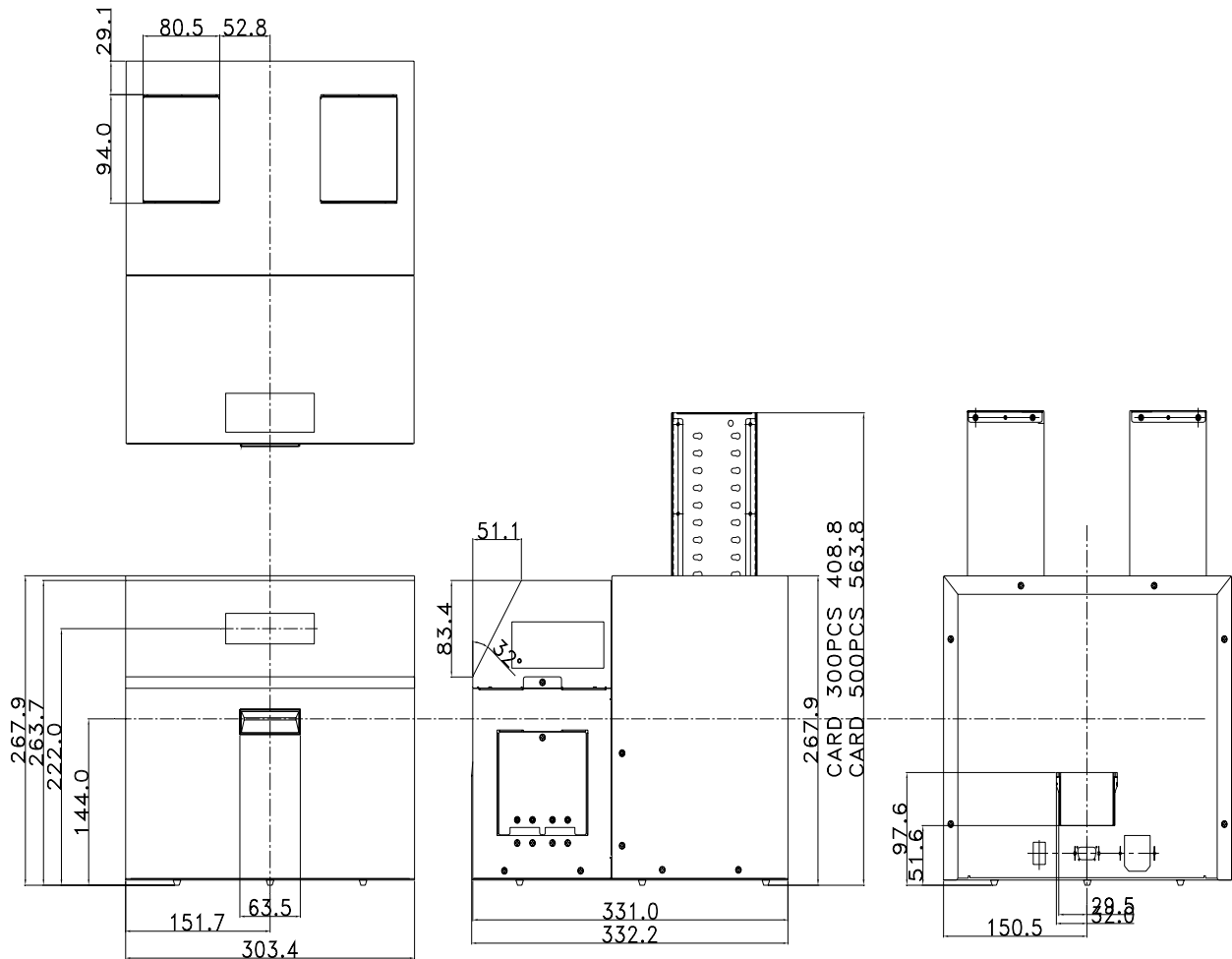

Doc No	CCM56XX SPECIFICATION	REV	PAGE	DATE
9100-0110		C	17 OF 41	2008. 12. 15.

< Feeder Part Sensor Position >

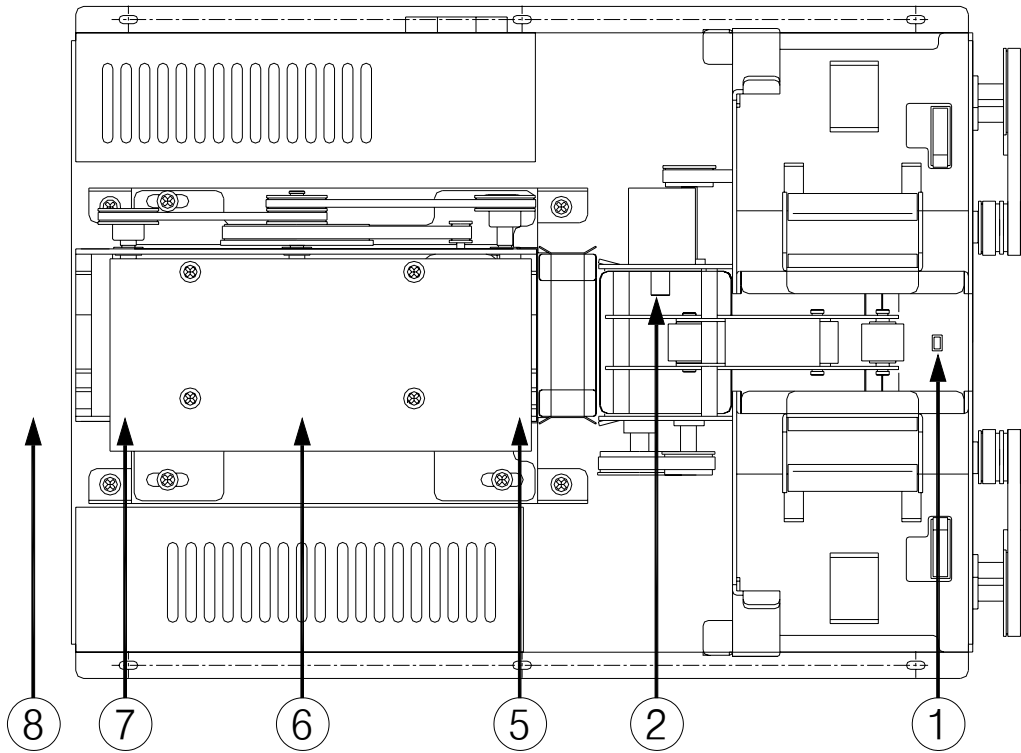

Doc No	CCM56XX SPECIFICATION	REV	PAGE	DATE
9100-0110		C	18 OF 41	2008. 12. 15.

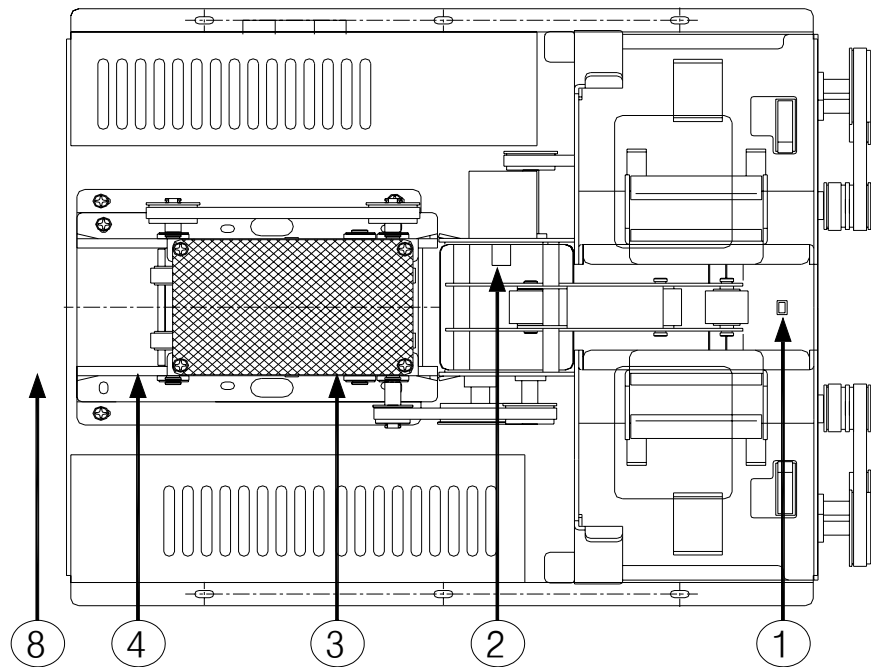
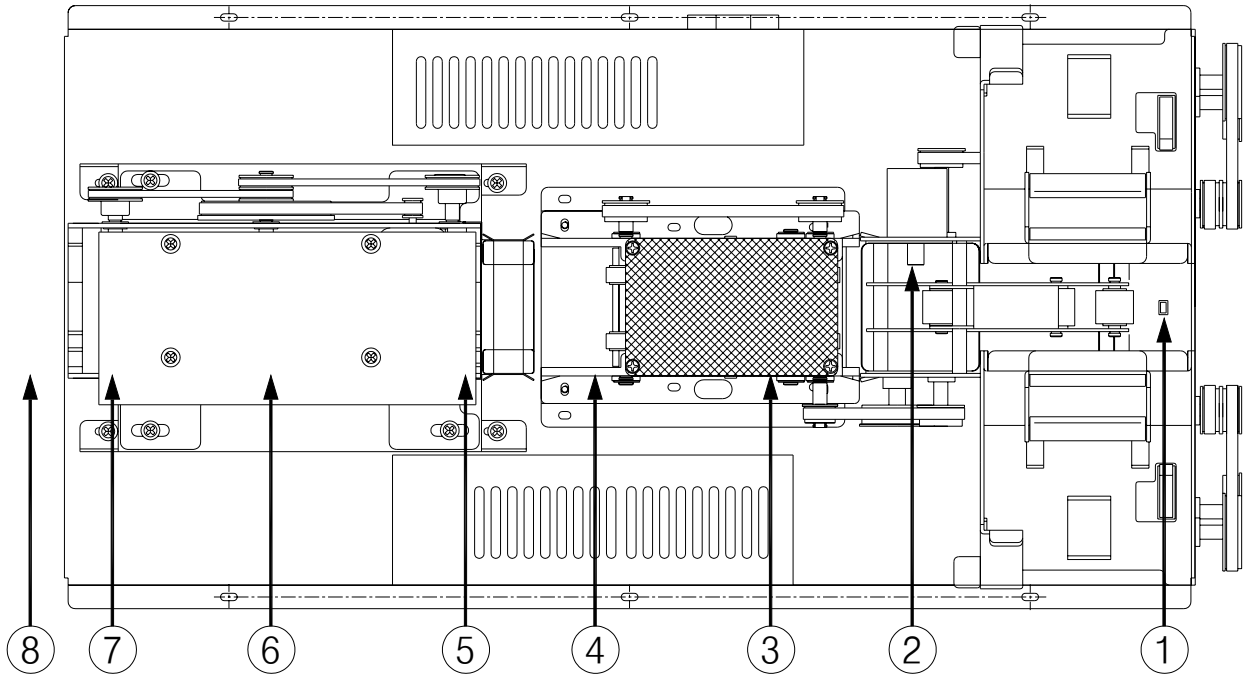

Doc No	CCM56XX SPECIFICATION	REV	PAGE	DATE
9100-0110		C	19 OF 41	2008. 12. 15.

COMMAND DETAIL

◆ *Applicable Models*

Commands	Models	Note
COMMON	All CCM5600 Series	

◆ *Command List*

	Item	Cm0	Cm1	Cm2	Detail	Note
COMMON	STATUS	'C'	'1'	'1'	Get Model	
		'C'	'1'	'2'	Get Firmware Version	
		'C'	'1'	'4'	Get Status List	
		'C'	'1'	'6'	Get Card Position	
		'C'	'1'	'A'	Get Cartridge Status	
	SETTING_1	'C'	'2'	'5'	Set Buzz On/Off Cont.	
		'C'	'2'	'9'	Cartridge Memory Initialization	
		'C'	'2'	'A'	Set the Number of Cartridge's Cards	
	MOVE	'C'	'3'	'1'	Card Move From Cartridge	
		'C'	'3'	'2'	Card Move To ...	
		'C'	'3'	'6'	Card Eject(Drop Mode)	
		'C'	'3'	'7'	Card Eject(Hold Mode)	
		'C'	'3'	'9'	Card Move To Cartridge	
	SETTING_2	C	'4'	'2'	Software Reset	
	RF CARD	RF CARD READ / WRITE	'R'	'3'	'1'	RF Card Read in Block Range
'R'			'3'	'2'	RF Card Write in Block Range	
'R'			'3'	'6'	RF Card Read in Sector Range	
'R'			'3'	'7'	RF Card Write in Sector Range	
BALANCE		'R'	'4'	'1'	Balance Increment	
		'R'	'4'	'2'	Balance Decrement	
SECRET KEY CHANGE		'R'	'5'	'1'	Change 'Secret Key' to other Key	
		'R'	'5'	'2'	Change 'Secret Key' to all the same Key value	
		'R'	'5'	'3'	Select 'Secret Key Index'	
		'R'	'5'	'4'	Change 'RF Card Secret Key' to other Key	
RF DETECT		'R'	'6'	'1'	Check RF card in antenna area	

Doc No	CCM56XX SPECIFICATION	REV	PAGE	DATE
9100-0110		C	20 OF 41	2008. 12. 15.

◆ *Common*

These are the command set that all the CCM56XX Series use. These commands include the terminal setting and the card movement related commands.

The 'STATUS' commands provide the function to check the current terminal status and the errors occurred during the command execution.

The 'SETTING' commands consist of commands for setting the terminal and these commands is easy to use because the same command can use for both setting and checking the terminal.

The 'MOVE' commands consist of commands used commonly like the card eject command.

Commands Set:

	Item	Cm0	Cm1	Cm2	Detail	Note
COMMON	STATUS	'C'	'1'	'1'	Get Model	
		'C'	'1'	'2'	Get Firmware Version	
		'C'	'1'	'4'	Get Status List	
		'C'	'1'	'6'	Get Card Position	
		'C'	'1'	'A'	Get Cartridge Status	
	SETTING_1	'C'	'2'	'4'	Set Retry Count	
		'C'	'2'	'9'	Cartridge Memory Initialization	
		'C'	'2'	'A'	Set the Number of Cartridge's Cards	
	MOVE	'C'	'3'	'1'	Card Move From Cartridge	
		'C'	'3'	'2'	Card Move To ...	
		'C'	'3'	'6'	Card Eject(Drop Mode)	
		'C'	'3'	'7'	Card Eject(Hold Mode)	
		'C'	'3'	'9'	Card Move To Cartridge	
	SETTING_2	C	'4'	'2'	Software Reset	

Doc No	CCM56XX SPECIFICATION	REV	PAGE	DATE
9100-0110		C	21 OF 41	2008. 12. 15.

1 STATUS / SETTING

1.1 “C11” : It is to check out Model number of CCM-56XX.

☞ Command Format

SOH	Null	Length	STX	“C11”	ETX	Bcc
-----	------	--------	-----	-------	-----	-----

☞ Positive Response Format

SOH	Null	Length	STX	“C11”	GOOD	0x01	DATA	ETX	Bcc
-----	------	--------	-----	-------	------	------	------	-----	-----

☞ Negative Response Format

SOH	Null	Length	STX	“C11”	E-Code	0x00	ETX	Bcc
-----	------	--------	-----	-------	--------	------	-----	-----

☞ Response Data Structure

Model No
30Byte (ASCII)

1.2 “C12” : It is to check out Firmware Version of CCM-56XX

☞ Command Format

SOH	Null	Length	STX	“C12”	ETX	Bcc
-----	------	--------	-----	-------	-----	-----

☞ Positive Response Format

SOH	Null	Length	STX	“C12”	GOOD	0x01	DATA	ETX	Bcc
-----	------	--------	-----	-------	------	------	------	-----	-----

☞ Negative Response Format

SOH	Null	Length	STX	“C12”	E-Code	0x00	ETX	Bcc
-----	------	--------	-----	-------	--------	------	-----	-----

☞ Response Data Structure

Firmware Version
30Byte (ASCII)

Doc No	CCM56XX SPECIFICATION	REV	PAGE	DATE
9100-0110		C	22 OF 41	2008. 12. 15.

1.3 “C14” : It is to check out current Status of CCM56XX

☞ Command Format

SOH	Null	Length	STX	“C14”	ETX	Bcc
-----	------	--------	-----	-------	-----	-----

☞ Positive Response Format

SOH	Null	HL	Length	“C14”	GOOD	0x01	DATA	ETX	Bcc
-----	------	----	--------	-------	------	------	------	-----	-----

☞ Negative Response Format

SOH	Null	Length	STX	“C14”	E-Code	0x00	ETX	Bcc
-----	------	--------	-----	-------	--------	------	-----	-----

☞ Response Data Structure

Error Code (1)	---	Error Code (N)
High Byte	Low Byte	
2Byte		

☞ Note

You can identify the stacker status, motor status, card status (jamming) and communication status through the Error Code in the response data structure.

1.4 “C16” : It is to check out current card position of CCM56XX

☞ Command Format

SOH	Null	Length	STX	“C16”	ETX	Bcc
-----	------	--------	-----	-------	-----	-----

☞ Positive Response Format

SOH	Null	Length	STX	“C16”	GOOD	0x01	DATA	ETX	Bcc
-----	------	--------	-----	-------	------	------	------	-----	-----

☞ Negative Response Format

SOH	Null	Length	STX	“C16”	E-Code	0x00	ETX	Bcc
-----	------	--------	-----	-------	--------	------	-----	-----

☞ Response Data Structure

Card Position
1Byte (Hex)

<Card Position> Refer to page 17.

Number	Code	Sensor
1	0x01	SEN1
2	0x02	SEN2
3	0x04	SEN3
4	0x08	SEN4
5	0x10	SEN5
6	0x20	SEN6
7	0x40	SEN7

Doc No	CCM56XX SPECIFICATION	REV	PAGE	DATE
9100-0110		C	23 OF 41	2008. 12. 15.

1.5 “C1A” : It is to check out the cartridge’s status.

☞ Command Format

SOH	Null	Length	STX	“C1A”	ETX	Bcc
-----	------	--------	-----	-------	-----	-----

☞ Positive Response Format

SOH	Null	Length	STX	“C21”	GOOD	0x01	DATA	ETX	Bcc
-----	------	--------	-----	-------	------	------	------	-----	-----

☞ Negative Response Format

SOH	Null	Length	STX	“C21”	E-Code	0x00	ETX	Bcc
-----	------	--------	-----	-------	--------	------	-----	-----

☞ Response Data Structure(14Byte)

Cartridge 1 ID	Cartridge 2 ID	The number of Cartridge1’s cards (Hexadecimal)	The number of Cartridge2’s cards (Hexadecimal)	Status of Cartridge1	Status of Cartridge2
4Byte	4Byte	2Byte	2Byte	1Byte	1Byte

< Cartridge ID >, < The number of cards in the cartridge >

High Byte ... Low Byte

< Status of Cartridge >

Code	Detail
0x01	Cartridge empty
0x02	There aren’t many cards left in the cartridge.(less than 30Cards)
0x04	No cartridge
0x08	Cartridge full(more than 300 cards)

Doc No	CCM56XX SPECIFICATION	REV	PAGE	DATE
9100-0110		C	24 OF 41	2008. 12. 15.

2 SETTING

2.1 “C25” : It is to set or to check ‘Buzz Control’.

☞ Command Format

SOH	Null	Length	STX	“C25”	DATA	ETX	Bcc
-----	------	--------	-----	-------	------	-----	-----

☞ Command Data Structure

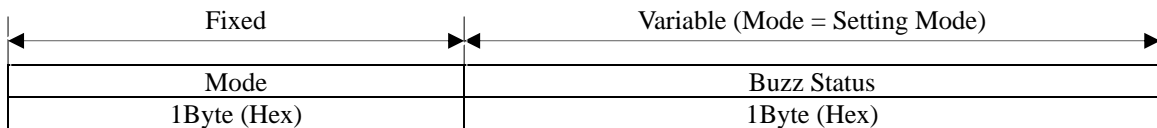

☞ Positive Response Format

SOH	Null	Length	STX	“C25”	GOOD	0x01	DATA	ETX	Bcc
-----	------	--------	-----	-------	------	------	------	-----	-----

☞ Negative Response Format

SOH	Null	Length	STX	“C25”	E-Code	0x00	ETX	Bcc
-----	------	--------	-----	-------	--------	------	-----	-----

☞ Response Data Structure

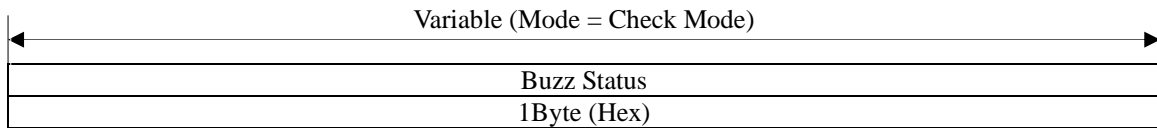

☞ Data Variable

<Mode>

Code	Mode	Detail
0x01	‘Setting Mode’	Set ‘Buzz Control’
0x02	‘Check Mode’	Check ‘Buzz Control’

<Buzz Status>

Code	Setting	Detail	Note
0x01	Buzz Off	Buzz Off	
0x02	Buzz On	Buzz On	Default

☞ Note

Doc No	CCM56XX SPECIFICATION	REV	PAGE	DATE
9100-0110		C	25 OF 41	2008. 12. 15.

2.2 “C29” : It is to initialize the cartridge’s memory.

☞ Command Format

SOH	Null	Length	STX	“C29”	DATA	ETX	Bcc
-----	------	--------	-----	-------	------	-----	-----

☞ Command Data Structure (7Byte)

Type	Cartridge ID	The number of cards in the cartridge(Hexadecimal)
1Byte	4Byte	2Byte

< Type >

Code	Detail
0x01	Cartridge1
0x02	Cartridge2

< Cartridge ID >, < The number of cards in the cartridge >

High Byte ... Low Byte

☞ Positive Response Format

SOH	Null	Length	STX	“C29”	GOOD	0x01	ETX	Bcc
-----	------	--------	-----	-------	------	------	-----	-----

☞ Negative Response Format

SOH	Null	Length	STX	“C29”	E-Code	0x00	ETX	Bcc
-----	------	--------	-----	-------	--------	------	-----	-----

2.3“C2A” : It is to set the number of cards in the cartridge.

☞ Command Format

SOH	Null	Length	STX	“C2A”	DATA	ETX	Bcc
-----	------	--------	-----	-------	------	-----	-----

☞ Command Data Structure (3Byte)

Type	The number of cards in the cartridge(Hexadecimal)
1Byte	2Byte

< Type >

Code	Detail
0x01	Cartridge1
0x02	Cartridge2

< The number of cards in the cartridge >

High Byte ... Low Byte

Doc No	CCM56XX SPECIFICATION	REV	PAGE	DATE
9100-0110		C	26 OF 41	2008. 12. 15.

3 MOVE

3.1 “C32” : It is take card to Card Reader / Writer Module

☞ Command Format

SOH	Null	Length	STX	“C32”	DATA	ETX	Bcc
-----	------	--------	-----	-------	------	-----	-----

☞ Command Data Structure

Module
1Byte (Hex)

☞ Positive Response Format

SOH	Null	Length	STX	“C32”	GOOD	0x01	DATA	ETX	Bcc
-----	------	--------	-----	-------	------	------	------	-----	-----

☞ Negative Response Format

SOH	Null	Length	STX	“C32”	E-Code	0x00	ETX	Bcc
-----	------	--------	-----	-------	--------	------	-----	-----

☞ Data Variable

<Module>

Code	Setting	Detail
0x01	Non-use	
0x02	Non-use	
0x03	RF	Card transport to RF Module

3.2 “C36” : It is to dispense out of the unit.(Drop)

☞ Command Format

SOH	Null	Length	STX	“C36”	ETX	Bcc
-----	------	--------	-----	-------	-----	-----

☞ Positive Response Format

SOH	Null	Length	STX	“C36”	GOOD	‘1’	ETX	Bcc
-----	------	--------	-----	-------	------	-----	-----	-----

☞ Negative Response Format

SOH	Null	Length	STX	“C36”	E-Code	‘0’	ETX	Bcc
-----	------	--------	-----	-------	--------	-----	-----	-----

3.3 “C37” : It is to dispense out card to the front. (Hold)

☞ Command Format

SOH	Null	Length	STX	“C37”	ETX	Bcc
-----	------	--------	-----	-------	-----	-----

☞ Positive Response Format

SOH	Null	Length	STX	“C37”	GOOD	‘1’	ETX	Bcc
-----	------	--------	-----	-------	------	-----	-----	-----

☞ Negative Response Format

SOH	Null	Length	STX	“C37”	E-Code	‘0’	ETX	Bcc
-----	------	--------	-----	-------	--------	-----	-----	-----

☞ Note

Doc No	CCM56XX SPECIFICATION	REV	PAGE	DATE
9100-0110		C	27 OF 41	2008. 12. 15.

3.3 “C39” : It is to take a card from Stacker and to move it to Card Reader / Writer Module.

☞ Command Format

SOH	Null	Length	STX	“C39”	DATA	ETX	Bcc
-----	------	--------	-----	-------	------	-----	-----

☞ Command Data Structure

Stacker
1Byte (Hex)

☞ Positive Response Format

SOH	Null	Length	STX	“C39”	GOOD	0x01	ETX	Bcc
-----	------	--------	-----	-------	------	------	-----	-----

☞ Negative Response Format

SOH	Null	Length	STX	“C39”	E-Code	0x00	ETX	Bcc
-----	------	--------	-----	-------	--------	------	-----	-----

☞ Data Variable

<Stacker>

Code	Setting	Detail
0x01	Stacker 1	Select Stacker 1
0x02	Stacker 2	Select Stacker 2
0x03	Auto	Select Stacker automatically

3.4 “C42” : Software RESET for Main Board

☞ Command Format

SOH	Null	Length	STX	“C42”	ETX	Bcc
-----	------	--------	-----	-------	-----	-----

☞ Positive Response Format

SOH	Null	Length	STX	“C42”	GOOD	0x01	ETX	Bcc
-----	------	--------	-----	-------	------	------	-----	-----

☞ Negative Response Format

SOH	Null	Length	STX	“C42”	E-Code	0x00	ETX	Bcc
-----	------	--------	-----	-------	--------	------	-----	-----

☞ Note

With this software RESET, all the data in the CCM56XX return to DEFAULT value.

After “RESET”, minimum 3 seconds is required before running to get secure operation.

Doc No	CCM56XX SPECIFICATION	REV	PAGE	DATE
9100-0110		C	28 OF 41	2008. 12. 15.

◆ *RF CARD*

This section describes the commands that can use at the 'RF CARD'.

The RF Module of his model supports only the MIFARE card.

The available commands are as follows.

Item	Cm0	Cm1	Cm2	Detail	Note
RF CARD READ /WRITE	'R'	'3'	'1'	Read RF card data in block range	
	'R'	'3'	'2'	Write RF card in block range	
	'R'	'3'	'6'	Read RF card in sector range	
	'R'	'3'	'7'	Write RF card in sector range	
BALANCE	'R'	'4'	'1'	Increment balance in RF card	
	'R'	'4'	'2'	Decrement balance in RF card	
CHANGE SECRET KEY	'R'	'5'	'1'	Change 'Secret Key' to other key	
	'R'	'5'	'2'	Change 'Secret Key' to all the same Key Value	
	'R'	'5'	'3'	Select 'Secret Key Index'	
	'R'	'5'	'4'	Change RF Card 'Secret Key' to other key	
RF DETECT	'R'	'6'	'1'	Check RF card in antenna area	

To use the RF card, you need to initialize at first.

- Setting and updating of the secret key and secret key index.

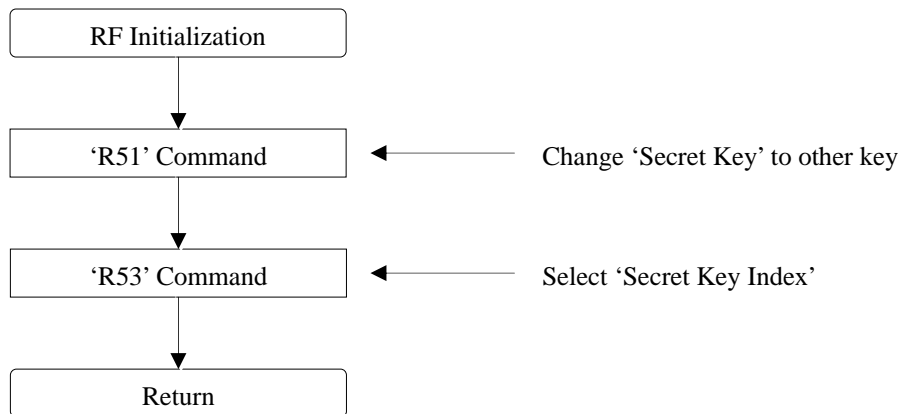

RF Module Initialization

Doc No	CCM56XX SPECIFICATION	REV	PAGE	DATE
9100-0110		C	29 OF 41	2008. 12. 15.

Basic Operating Procedure of the RF card:

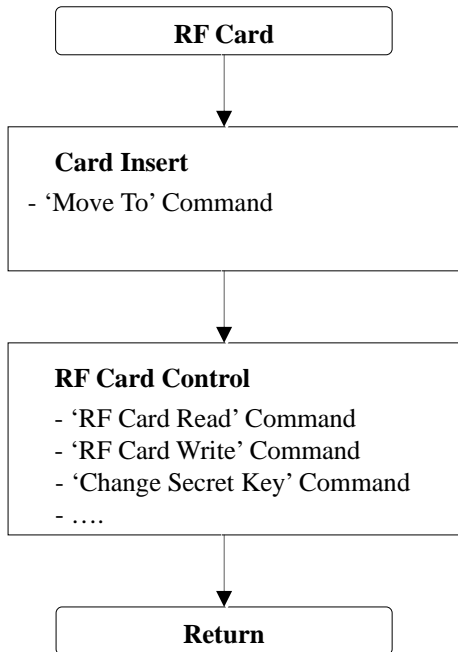

RF Card Basic Operating Procedures

Memory Architecture(map) of the RF card: 8Kbit

Sector	Block	Size	Detail	Note
Sector 0	Block 0	16Byte	RF Card Information	Can't use
	Block 1	16Byte		
	Block 2	16Byte	'Sector Key'	
	Block 3	16Byte		
Sector 1	Block 0	16Byte	User Available Memory	
	Block 1	16Byte		
	Block 2	16Byte	'Sector Key'	
	Block 3	16Byte		
Sector 2	Block 0	16Byte	User Available Memory	
	Block 1	16Byte		
	Block 2	16Byte	'Sector Key'	
	Block 3	16Byte		
---	---	---	---	---
Sector 15	Block 0	16Byte	User Available Memory	
	Block 1	16Byte		
	Block 2	16Byte	'Sector Key'	
	Block 3	16Byte		

Doc No	CCM56XX SPECIFICATION	REV	PAGE	DATE
9100-0110		C	30 OF 41	2008. 12. 15.

1 RF CARD READ / WRITE

1.1 "R31" : Read RF card data & Secret Key in block range

☞ Command Format

SOH	Null	Length	STX	"R31"	DATA	ETX	Bcc
-----	------	--------	-----	-------	------	-----	-----

☞ Command Data Structure

Sector	Block
0x00 – 0x0f	0x00 – 0x03
1Byte (Hex)	1Byte (Hex)

☞ Positive Response Format

SOH	Null	Length	STX	"R31"	GOOD	0x01	DATA	ETX	Bcc
-----	------	--------	-----	-------	------	------	------	-----	-----

☞ Negative Response Format

SOH	Null	Length	STX	"R31"	E-Code	0x00	ETX	Bcc
-----	------	--------	-----	-------	--------	------	-----	-----

☞ Response Data Structure

Sector	Block	Read Data
1Byte (Hex)	1Byte (Hex)	16 Byte (Hex)

D0	D1	D2	---	D14	D15
1Byte	1Byte	1Byte	---	1Byte	1Byte

1.2 "R32" : Write RF card data in block range

☞ Command Format

SOH	Null	Length	STX	"R32"	DATA	ETX	Bcc
-----	------	--------	-----	-------	------	-----	-----

☞ Command Data Structure

Sector	Block	Write Data
0x00 – 0x0f	0x00 – 0x02	0x00 – 0xff
1Byte (Hex)	1Byte (Hex)	16Byte (Hex)

D0	D1	D2	---	D14	D15
1Byte	1Byte	1Byte	---	1Byte	1Byte

☞ Positive Response Format

SOH	Null	Length	STX	"R32"	GOOD	0x01	ETX	Bcc
-----	------	--------	-----	-------	------	------	-----	-----

☞ Negative Response Format

SOH	Null	Length	STX	"R32"	E-Code	0x00	ETX	Bcc
-----	------	--------	-----	-------	--------	------	-----	-----

Doc No	CCM56XX SPECIFICATION	REV	PAGE	DATE
9100-0110		C	31 OF 41	2008. 12. 15.

1.3 “R36” : Read RF card data in sector range

☞ Command Format

SOH	Null	Length	STX	“R36”	DATA	ETX	Bcc
-----	------	--------	-----	-------	------	-----	-----

☞ Command Data Structure

Sector
0x00 – 0x0f
1Byte (Hex)

☞ Positive Response Format

SOH	Null	Length	STX	“R36”	GOOD	0x01	DATA	ETX	Bcc
-----	------	--------	-----	-------	------	------	------	-----	-----

☞ Negative Response Format

SOH	Null	Length	STX	“R36”	E-Code	0x00	ETX	Bcc
-----	------	--------	-----	-------	--------	------	-----	-----

☞ Response Data Structure

0x00	Read Data (0)	0x01	Read Data (1)	0x02	Read Data (2)
1Byte (Hex)	16Byte (Hex)	1Byte (Hex)	16Byte (Hex)	1Byte (Hex)	16Byte (Hex)

D0	D1	D2	---	D14	D15
1Byte	1Byte	1Byte	---	1Byte	1Byte

1.4 “R37” : Write RF card data in sector range (except Sector 0)

☞ Command Format

SOH	Null	Length	STX	“R37”	DATA	ETX	Bcc
-----	------	--------	-----	-------	------	-----	-----

☞ Command Data Structure

Sector	Write Data
0x01 – 0x0f	0x00 – 0xff
1Byte (Hex)	51Byte (Hex)

0x00	Read Data (0)	0x01	Read Data (1)	0x02	Read Data (2)
1Byte (Hex)	16Byte (Hex)	1Byte (Hex)	16Byte (Hex)	1Byte (Hex)	16Byte (Hex)

D0	D1	D2	---	D14	D15
1Byte	1Byte	1Byte	---	1Byte	1Byte

☞ Positive Response Format

SOH	Null	Length	STX	“R37”	GOOD	0x01	ETX	Bcc
-----	------	--------	-----	-------	------	------	-----	-----

☞ Negative Response Format

SOH	Null	Length	STX	“R37”	E-Code	0x00	ETX	Bcc
-----	------	--------	-----	-------	--------	------	-----	-----

Doc No	CCM56XX SPECIFICATION	REV	PAGE	DATE
9100-0110		C	32 OF 41	2008. 12. 15.

2 BALANCE

2.1 “R41” : Increment the balance of card to the specified amount.

Command Format

SOH	Null	Length	STX	“R41”	DATA	ETX	Bcc
-----	------	--------	-----	-------	------	-----	-----

Command Data Structure

Sector	Block	Index Value
0x00 – 0x0f	0x00 – 0x02	0x00000000 – 0xffffffff
1Byte (Hex)	1Byte (Hex)	4Byte (Hex)

V0	V1	V2	V3
0x00-0xff	0x00-0xff	0x00-0xff	0x00-0xff
1Byte(Hex, LSB)	1Byte(Hex)	1Byte(Hex)	1Byte(Hex, MSB)

Positive Response Format

SOH	Null	Length	STX	“R41”	GOOD	0x01	ETX	Bcc
-----	------	--------	-----	-------	------	------	-----	-----

Negative Response Format

SOH	Null	Length	STX	“R41”	E-Code	0x00	ETX	Bcc
-----	------	--------	-----	-------	--------	------	-----	-----

Note

The balance should be written in the Electronic Purse format in the card.

2.1 “R42” : Decrement the balance of card to the specified amount..

Command Format

SOH	Null	Length	STX	“R42”	DATA	ETX	Bcc
-----	------	--------	-----	-------	------	-----	-----

Command Data Structure

Sector	Block	Index Value
0x00 – 0x0f	0x00 – 0x02	0x00000000 – 0xffffffff
1Byte (Hex)	1Byte (Hex)	4Byte (Hex)

V0	V1	V2	V3
0x00-0xff	0x00-0xff	0x00-0xff	0x00-0xff
1Byte(Hex, LSB)	1Byte(Hex)	1Byte(Hex)	1Byte(Hex, MSB)

Positive Response Format

SOH	Null	Length	STX	“R42”	GOOD	0x01	ETX	Bcc
-----	------	--------	-----	-------	------	------	-----	-----

Negative Response Format

SOH	Null	Length	STX	“R42”	E-Code	0x00	ETX	Bcc
-----	------	--------	-----	-------	--------	------	-----	-----

Note

The balance should be written in the Electronic Purse format in the card.

Doc No	CCM56XX SPECIFICATION	REV	PAGE	DATE
9100-0110		C	33 OF 41	2008. 12. 15.

3 SECRET KEY

3.1 “R51” : Change ‘Secret Key’ to a new key

☞ Command Format

SOH	Null	Length	STX	“R51”	DATA	ETX	Bcc
-----	------	--------	-----	-------	------	-----	-----

☞ Command Data Structure

Sector	KEY A	KEY B
0x00 – 0x0f	0x00 – 0xff	0x00 – 0xff
1Byte (Hex)	6Byte (Hex)	6Byte (Hex)

☞ Positive Response Format

SOH	Null	Length	STX	“R51”	GOOD	0x01	ETX	Bcc
-----	------	--------	-----	-------	------	------	-----	-----

☞ Negative Response Format

SOH	Null	Length	STX	“R51”	E-Code	0x00	ETX	Bcc
-----	------	--------	-----	-------	--------	------	-----	-----

☞ Note

CCM56XX Series ‘Secret Key’ Default – Key Set 0

KEY A : FFFFFFFFFF

KEY B : FFFFFFFFFF

3.2 “R52” : Change ‘Secret Key’ to all the same key value

☞ Command Format

SOH	Null	Length	STX	“R52”	DATA	ETX	Bcc
-----	------	--------	-----	-------	------	-----	-----

☞ Command Data Structure

KEY A	KEY B
0x00 – 0xff	0x00 – 0xff
6Byte (Hex)	6Byte (Hex)

☞ Positive Response Format

SOH	Null	Length	STX	“R52”	GOOD	0x01	ETX	Bcc
-----	------	--------	-----	-------	------	------	-----	-----

☞ Negative Response Format

SOH	Null	Length	STX	“R52”	E-Code	0x00	ETX	Bcc
-----	------	--------	-----	-------	--------	------	-----	-----

☞ Note

CCM56XX Series ‘Secret Key’ Default – Key Set 0

KEY A : FFFFFFFFFF

KEY B : FFFFFFFFFF

Doc No	CCM56XX SPECIFICATION	REV	PAGE	DATE
9100-0110		C	34 OF 41	2008. 12. 15.

3.3 “R53” : Select ‘Secret Key Index’

☞ Command Format

SOH	Null	Length	STX	“R53”	DATA	ETX	Bcc
-----	------	--------	-----	-------	------	-----	-----

☞ Command Data Structure

Index
0x01 – 0x02
1Byte (Hex)

☞ Positive Response Format

SOH	Null	Length	STX	“R53”	GOOD	0x01	ETX	Bcc
-----	------	--------	-----	-------	------	------	-----	-----

☞ Negative Response Format

SOH	Null	Length	STX	“R53”	E-Code	0x00	ETX	Bcc
-----	------	--------	-----	-------	--------	------	-----	-----

☞ Data Variable

<Index>

Code	Setting	Detail
0x01	KEY A	Select ‘Secret Key A’
0x02	KEY B	Select ‘Secret Key B’

☞ Note

CCM56XX Series ‘Secret Key Index’ Default

‘Secret Key Index ‘ : KEY A

3.4 “R54” : Change RF card ‘Secret Key’ to other key

☞ Command Format

SOH	Null	Length	STX	“R54”	DATA	ETX	Bcc
-----	------	--------	-----	-------	------	-----	-----

☞ Command Data Structure

- Command data structure without ‘Access Condition’

Sector	KEY A	KEY B
0x00 – 0x0f	0x00 – 0xff	0x00 – 0xff
1Byte (Hex)	6Byte (Hex)	6Byte (Hex)

- Command data structure with ‘Access Condition’

Sector	KEY A	Access	KEY B
0x00 – 0x0f	0x00 – 0xff	0x00 – 0xff	0x00 – 0xff
1Byte (Hex)	6Byte (Hex)	4Byte (Hex)	6Byte (Hex)

☞ Positive Response Format

SOH	Null	Length	STX	“R54”	GOOD	0x01	ETX	Bcc
-----	------	--------	-----	-------	------	------	-----	-----

☞ Negative Response Format

SOH	Null	Length	STX	“R54”	E-Code	0x00	ETX	Bcc
-----	------	--------	-----	-------	--------	------	-----	-----

☞ Warning

If you use this command incorrectly, it couldn’t be authenticated from the card.

Doc No	CCM56XX SPECIFICATION	REV	PAGE	DATE
9100-0110		C	35 OF 41	2008. 12. 15.

4 RF DETECT

4.1 “R61” : RF card detect in antenna area

☞ Command Format

SOH	Null	Length	STX	“R61”	ETX	Bcc
-----	------	--------	-----	-------	-----	-----

☞ Positive Response Format

SOH	Null	Length	STX	“R61”	GOOD	DATA	0x01	ETX	Bcc
-----	------	--------	-----	-------	------	------	------	-----	-----

☞ Negative Response Format

SOH	Null	Length	STX	“R61”	E-Code	0x00	ETX	Bcc
-----	------	--------	-----	-------	--------	------	-----	-----

☞ Response Data Structure

Serial Number
Hex Code
4Byte

☞ Note

If the RF card is detected, this command send the serial number to host. But, it doesn't authenticate the Secret Key of the RF card.

Doc No	CCM56XX SPECIFICATION	REV	PAGE	DATE
9100-0110		C	36 OF 41	2008. 12. 15.

ERROR DETAIL

<GOOD>

Code : 0x0000

Description: Normal Execution

Procedures: None

<NOT_DEFINE_COMMAND>

Code : 0x2001

Description : Using the command that does not defined in this model.

Action : Use the valid command in this model.

<NOT_USE_COMMAND>

Code : 0x2002

Description : Not available command in this model.

Action : Use the valid command in this model.

<COMM_FRAME_ERROR>

Code : 0x2003

Description : Sending the command that has the invalid communication frame.

Action : Check the data format and the corresponding module specification.

<CARD_JAM>

Code : 0x2004

Description : When the card is jammed.

Action : Remove the jammed card.

<NO_CARD>

Code : 0x2005

Description : No cards.

Action : Insert the card.

Doc No	CCM56XX SPECIFICATION	REV	PAGE	DATE
9100-0110		C	37 OF 41	2008. 12. 15.

<CARD_PRESENT>

Code : 0x2006

Description : When the card exists already in the terminal.

Action : Eject the card.

<BUSY>

Code : 0x2007

Description : When the terminal is running or busy.

Action : Wait until the previous operation is completed.

<TWO_CART_ERROR>

Code : 0x2009

Description : When more than one card is presented in the feeder part.

Action : Remove one card.

<CARTRIDGE_JAM_ERROR>

Code : 0x200c

Description : When the cartridge is jammed.

Action : Check if the cartridge is normal.

<NO_CARTRIDGE_ERROR>

Code : 0x200d

Description : When the cartridge is not presented.

Action : Equip the cartridge.

<INVALID_POS_ERROR>

Code : 0x200e

Description : When the card is presented in the invalid position for the received command.

Action : Check the card position..

<CARTRIDGE1_MEMORY_ERROR>

Code : 0x2010

Description : When the memory data of the cartridge1 is incorrect.

Action : Replace the memory of the cartridge1

Doc No	CCM56XX SPECIFICATION	REV	PAGE	DATE
9100-0110		C	38 OF 41	2008. 12. 15.

<CARTRIDGE2_MEMORY_ERROR>

Code : 0x2011

Description : When the memory data of the cartridge2 is incorrect.

Action : Replace the memory of the cartridge2

<CARTRIDGE1_ERROR>

Code : 0x2102

Description : The first CARTRIDGE ERROR

Action : Be sure that the card is loaded at the first stacker.

<CARTRIDGE2_ERROR>

Code : 0x2103

Description: The second CARTRIDGE ERROR

Action : Be sure that the card is loaded at the second cartridge.

<CARTRIDGE1_EMPTY>

Code : 0x2105

Description : No card at the first cartridge.

Action : Load the card at the first cartridge.

<CARTRIDGE2_EMPTY>

Code : 0x2106

Description : No card at the second stacker.

Action : Load the card at the second stacker.

<CARTRIDGE1_WARNING>

Code : 0x2107

Description : Too few cards in the first stacker.

Action : Load the card at the first stacker.

<CARTRIDGE2_WARNING>

Code : 0x2108

Description : Too few cards in the second stacker.

Action : Load the card at the second stacker.

Doc No	CCM56XX SPECIFICATION	REV	PAGE	DATE
9100-0110		C	39 OF 41	2008. 12. 15.

<BIN_FULL>

Code : 0x2109

Description : Too many cards in the 'CAPTURE BOX'.

Action : Keep the capture box empty.

<BOTH_CARTRIDGE_FUL>

Code : 0x2110

Description : CARTRIDGE_1 and CARTRIDGE_1 are FULL.

Action : Replace the cartridge 1 and the cartridge 2.

<BOTH_CARTRIDGE_1_FUL>

Code : 0x2111

Description : CARTRIDGE_1 is FULL.

Action : Replace the cartridge 1.

<BOTH_CARTRIDGE_2_FUL>

Code : 0x2112

Description : CARTRIDGE_2 is FULL.

Action : Replace the cartridge 2.

Doc No	CCM56XX SPECIFICATION	REV	PAGE	DATE
9100-0110		C	40 OF 41	2008. 12. 15.

<RF_ERROR>

Code : 0x2300

Description : Unavailable RF module.

Action : Change the RF MODULE

<RF_COMM_ERROR>

Code : 0x2301

Description : Communication error at the RF Module.

Action : Check the connection socket

<RF_AUTHEN_ERROR>

Code : 0x2302

Description : Authentication Error at the RF Module.

Action : Change the 'SECRET KEY'

<RF_WRITE_ERROR>

Code : 0x2303

Description : Error while the terminal writes at the RF Card.

Action : Be sure that the card exists in the detection range.

<RF_READ_ERROR>

Code : 0x2304

Description : Error while the terminal reads at the RF Card.

Action: Be sure that the card exists in the detection range.

<RF_DETECT_ERROR>

Error Code : 0x2305

Description : No RF Card.

Action : Insert the RF Card into the terminal.

<RF_AMOUNT_ERROR>

Error Code : 0x2306

Description : Error while the terminal increases(or decreases) the balance at the RF card.

Action : Tune the RF module.

Doc No	CCM56XX SPECIFICATION	REV	PAGE	DATE
9100-0110		C	41 OF 41	2008. 12. 15.

Precautions

1. Check if the card exists in cartridge. Otherwise, it may not collect the card.

2. Check the communication line
 - 1) Communication Port, Baud, Parity, and Data Bit, etc.